

INSTRUCTION MANUAL

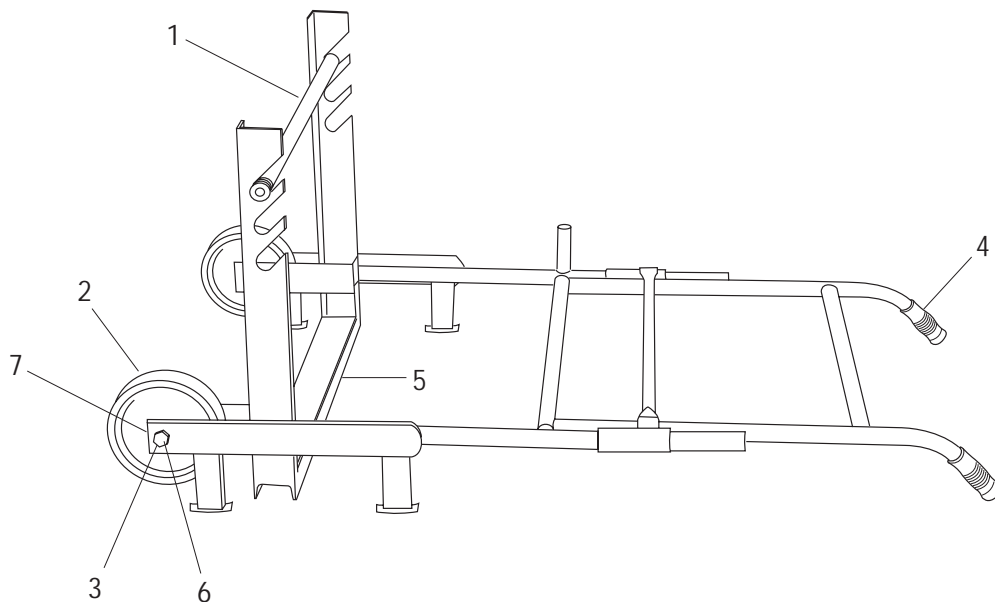

916 REEL TRANSPORTER



Capacity: Reels of cable or BX up to 20" wide and 40" in diameter. Maximum total reel weight: 300 lbs.

Service Information for Earlier Models

If ordering the Wheel Kit, use the two sleeves to make the current wheel with 3/4" bore compatible with the previous 916 design with 5/8" diameter axle. Use the 905 2466.7 washers on outer end of each axle to prevent wheel from contacting U-frame. If your current axle is 3/4" diameter, simply discard the sleeve.

Parts List

KEY	PART NO.	DESCRIPTION	QTY.
1	500 3035.7	Spool Spindle	1
2	905 2466.7	Wheel Kit	2
3	500 4757.4	Axle	2
4	503 3406.9	Grip	2
5	503 3481.6	Bumper Strip	2
6	905 0283.3	Retaining Ring 5100-750	4
7	905 4850.7	Washer	2

SAVE THESE INSTRUCTIONS

Additional copies of this manual are available upon request at no charge.

GREENLEE **TEXTRON**

Greenlee Textron / Subsidiary of Textron Inc.
 4455 Boeing Drive, Rockford, IL 61109-2988 USA
 Customer Service (International): 815/397-7070 • Fax: 815/397-1391
 Customer Service (North America): 800/435-0786 • Fax: 800/451-2632, 815/397-1865
 Canada Fax: 800/524-2853 Printed in the U.S.A.